

REB-1315S4 Operational Manual

Version 0.1
2012/09/12

This document contains information highly confidential to RoyalTek Company LTD (RoyalTek). It is provided for the sole purpose of the business discussions between customer and RoyalTek and is covered under the terms of the applicable Non-Disclosure Agreements. Disclosure of this information to other parties is prohibited without the written consent of RoyalTek.

Prepared by RoyalTek Company LTD.

4F., No.188, Wen Hwa 2nd Rd., Kuei Shan,
Tao Yuan 333, Taiwan

TEL: 886-3-3960001

FAX: 886-3-3960065

<http://www.royaltek.com/contact>

Approved by	Checked by	Prepared by

Content

1. Introduction	2
1.1 Product Applications	2
2. Product Pictures.....	3
3. REB-1315S4 Block Diagram.....	3
4. REB-1315S4 Technical Specification	4
5. Reference schematic:.....	5
6. Recommend layout PAD:.....	8
7. Mechanical diagram	9
8. Interface pin definition	9
9. Software Interface	11
10.Package Specification and Order Information.....	16
11.Contact Royaltek	16
Revision History	16

1. Introduction

RoyalTek REB-1315S4 is the GPS module of SiRFstar IV. The module is powered by latest SiRF Star IV GSD4e ROM chip and RoyalTek proprietary navigation technology that provides you with stable and accurate navigation data. The suitable form factor and miniature design is the best choice to be embedded in a device such as portable navigation device, personal locator, speed camera detector and vehicle locator.

Product Features

- 2 48 track verification channels
- 2 Power supply 3.3V voltage.
- 2 SMT type with stamp holes
- 2 Small form factor with embedded SiRF Star IV technology.
- 2 Removes in-band jammers up to 80 dB-Hz, track up to 8 CW jammers
- 2 Excellent sensitivity for urban canyon and foliage environments.

1.1 Product Applications

- 2 Automotive navigation
- 2 Personal positioning and navigation
- 2 Mobile gaming
- 2 Cameras
- 2 Asset Tracking
- 2 Others location-aware consumer devices

2. Product Pictures



3. REB-1315S4 Block Diagram

System block diagram description:

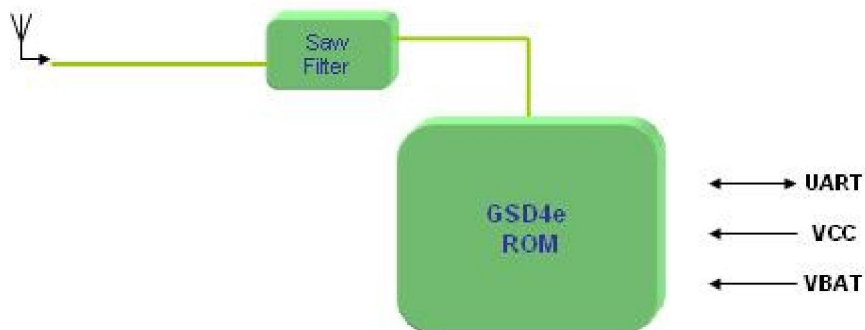

4. REB-1315S4 Technical Specification

Impedance : 50

No	Function	Specification
GPS receiver		
1	Chipset	SiRF Star IV, GSD4e ROM version (SiRF-9333)
2	Frequency	L1 1575.42MHz.
3	Code	C.A. Code.
4	Channels	48 track verification channels
5	Sensitivity	- Tracking Sensitivity -159dBm - Autonomous Acquisition -148dBm
6	Chipset Cold start (open sky)	35 sec
7	Chipset Warm start (open sky)	35 sec
8	Chipset Hot start (open sky)	1 sec
9	Reacquisition	0.1sec typical
10	Position accuracy	within 10m for 90% (24hr static, -130dBm)
11	Maximum altitude	18000 m
12	Maximum velocity	515 m/s
13	Update rate	1Hz
14	Protocol	Default 9600bps GGA(1),GSA(1),GSV(5),RMC(1)
Interface		
15	I/O Pin	22pins
Power consumption		
16	Vcc	DC +3.3V@ ±5%
17	Current	Normal mode: VCC_IN CURRENT TYP. 40mA@3.3V(without ext. antenna) Hibernate mode :VBATT current TYP. 20uA@3.3V(without ext. antenna)
Mechanical requirements		
18	Dimension(mm)	13 ±0.2 x 15.2 ±0.2 x 2.2 ±0.25mm
19	Weight	3g
Environment		
20	Operating/Storage	Operating : -30 ~ 85

	temperature	Storage: -40 ~ 85
21	Humidity	95%

5. Reference schematic:

For example:

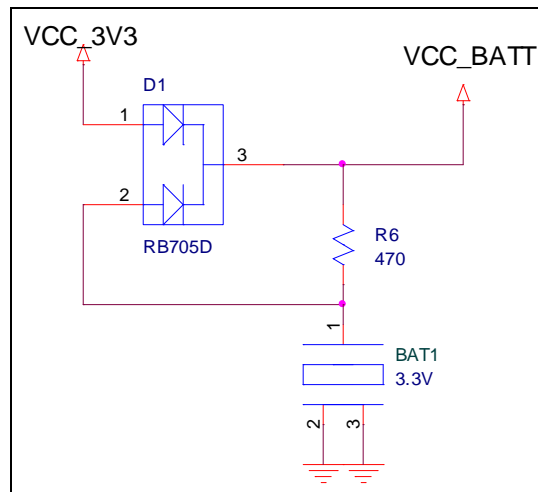
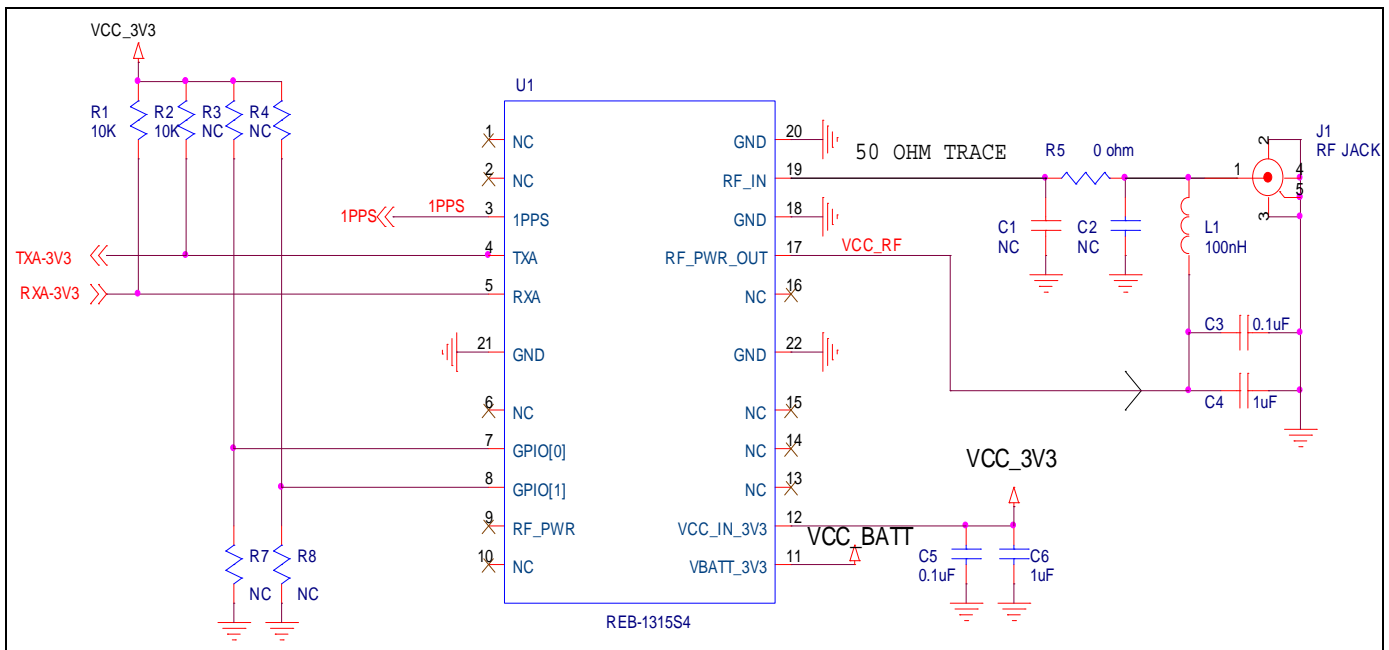

n **VCC_IN (DC 3.3V@ 5% power Input)**

This is the DC power supply input pin for GPS system. It provides voltage to module. The power supply must add bypass capacitor (10uF and 1uF). It can reduce the Noise from power supply and increase power stability.

If shutdown the REB-1315S4 module, please remove the VCC_IN Pin voltage into Hibernate mode.(It's will keep the Warm start and Hot start function work well)

n **RF_GND**

GND provides the ground.

n **RXD**

This is the main receiver channel and is used to receive software commands to the board from SIRFdemo software or from user written software.

n **TXD**

This is the main transmitting channel and is used to output navigation and measurement data to SiRFdemo or user written software.

n **RF_IN**

Connecting to the antenna has to be routed on the PCB. The transmission line must to be control impedance from RF_IN pin to the antenna or antenna connector of your choice. (Impedance 50)

Note: Recommend used Active antenna (Gain 27).

n **VCC_RF_VOUT**

This pin can provide maximum power 30mA@3.3V for active antenna

n **1PPS (TIMEMARK)**

This pin provides one pulse-per-second output from the board, which is synchronized to GPS time. Need firmware supporting. If don't used, can open.

n **V_BATT (Backup Battery)**

This is the battery backup input that powers supply the Hibernate mode when main power is removed. It's will keep the Warm start and Hot start function work well. Typical current draw is 20uA.

The supply voltage should be between 2.2V and 3.3V.

n **GPIO [0,1] (Can used HW switch baud rate)**

It is for baud rate setting. Default Baud rate is 9600 bps.

HW switch baud rate setup

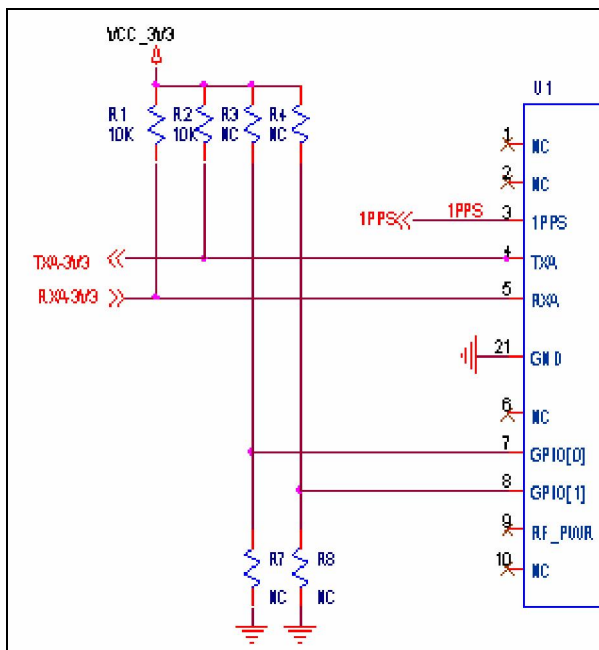

Baud rate(bps)	PIN8_GPIO[1]	PIN7_GPIO[0]	Default
4800	Pull HIGH(Suggest R4 use 1K ohm)	OPEN	
9600	OPEN	OPEN	V
38400	OPEN	Pull LOW(Suggest R7 use 1K ohm)	

I2C_SDA Internal Pull up resistor 10K ohm

I2C_CLK Internal Pull down resistor 2.2K ohm

6. Recommend layout PAD:

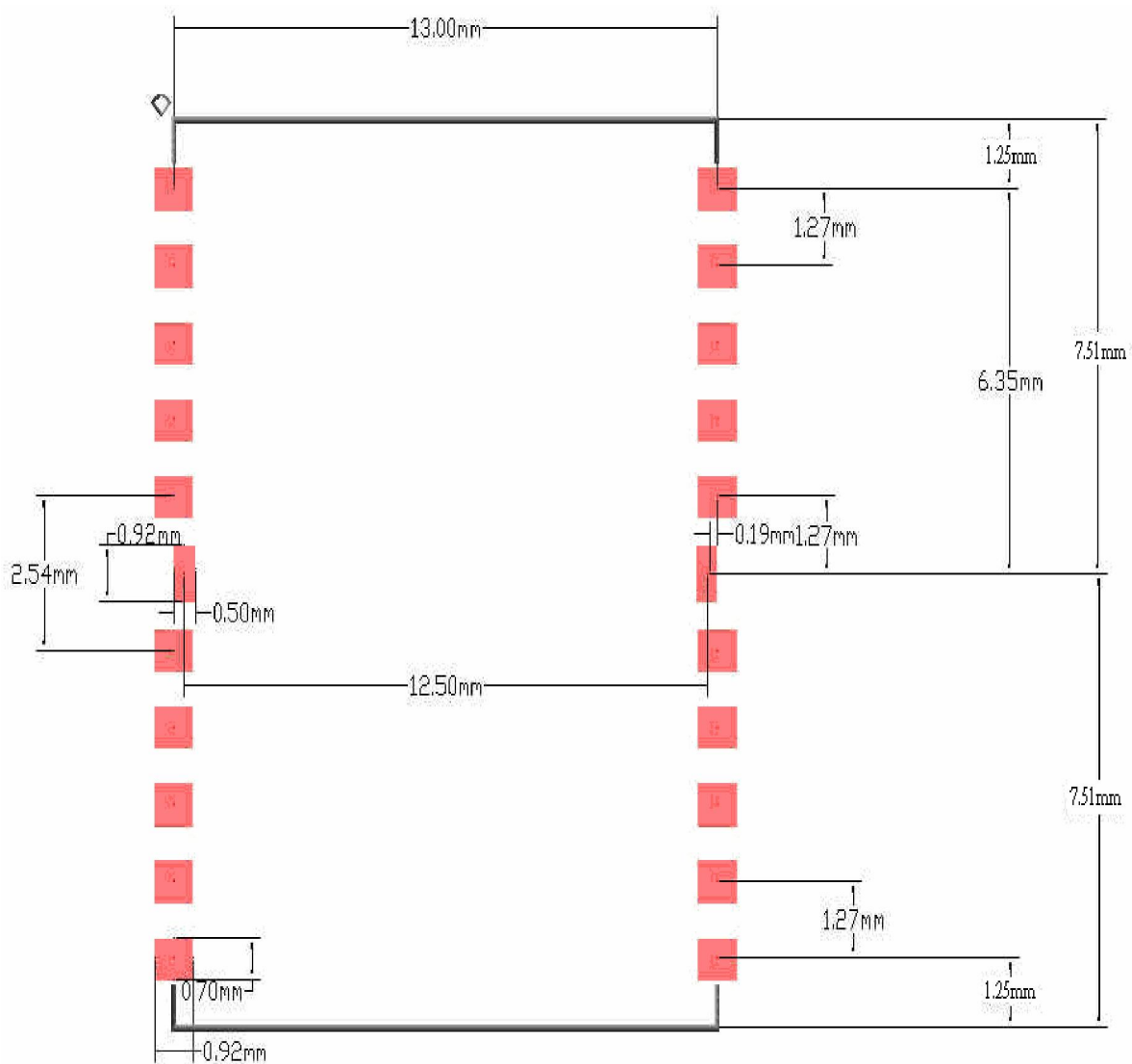

7. Mechanical diagram

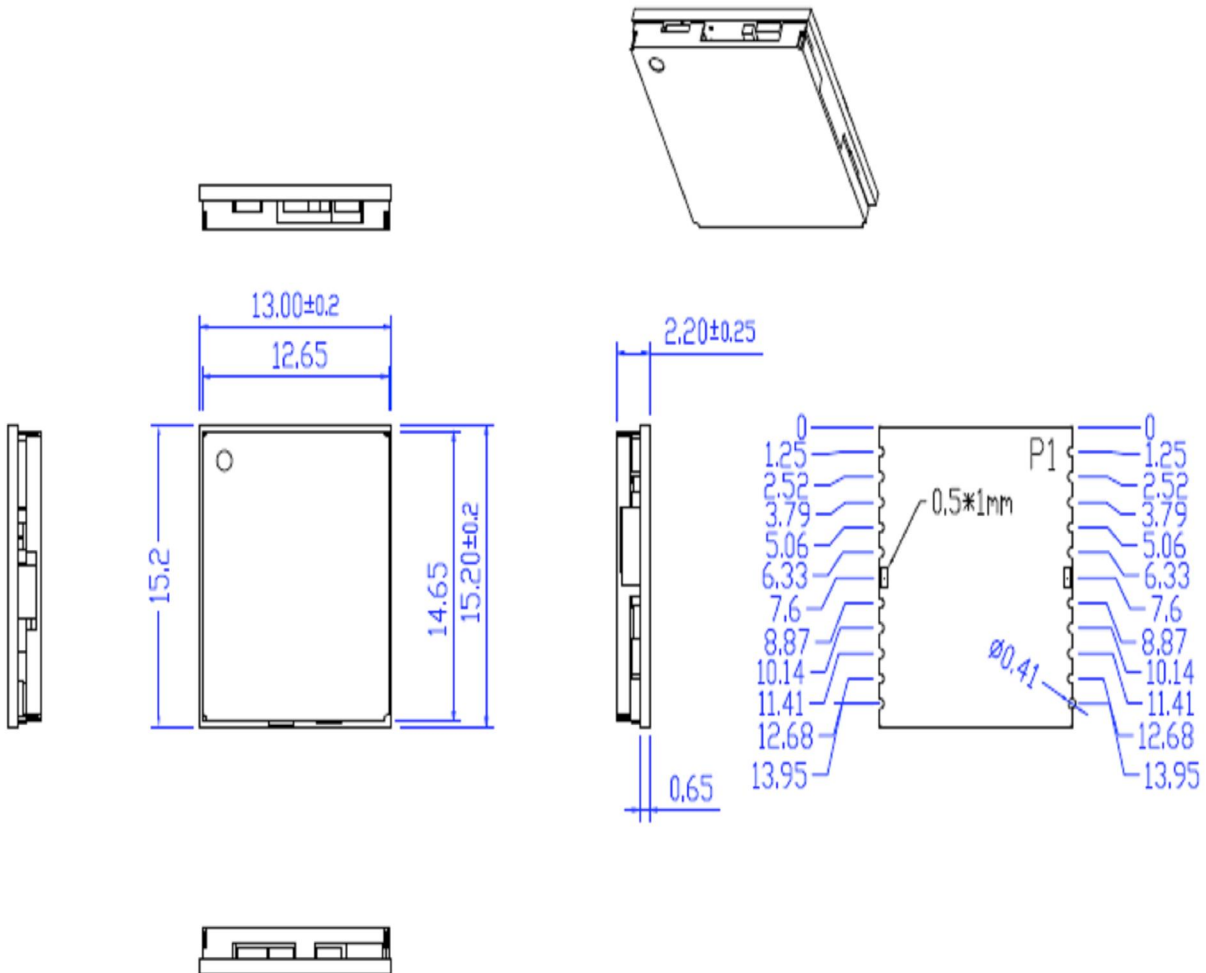

8. Interface pin definition

Pin definition:

Pin number	Pin function	Type	Description	ELECTRICAL CHARACTERISTICS
1	NC	~	NO CONNECTION	
2	NC	~	NO CONNECTION	
3	1PPS	O	1PPS TIMEMARK PULSE	200mS ACTIVE HIGH VOL <0.4V, VOH >2.2V
4	TXA	O	UART SERIAL DATA OUTPUT	VOL <0.4V, VOH >2.2V

5	RXA	I	UART SERIAL DATA INPUT	VIL <0.45V, 1.26V<VIH <3.6V
6	NC	~	NO CONNECTION	
7	GPIO[0]	I	Baud rate setup	VIL <0.45V, 1.26V<VIH <3.6V
8	GPIO[1]	I	Baud rate setup	VIL <0.45V, 1.26V<VIH <3.6V
9	RF_PWR	P	NO CONNECTION	
10	NC	~	NO CONNECTION	
11	V_BATT	P	BACK UP BATTERY VOLTAGE INPUT	2.2V MIN. 3V TYP. 3.3V MAX.
12	VCC_IN	P	SUPPLY MAIN VOLTAGE INPUT	2.85V MIN. 3.3V TYP. 3.6V MAX.
13	GND	P	GROUND	
14	NC	~	NO CONNECTION	
15	NC	~	NO CONNECTION	
16	NC	~	NO CONNECTION	
17	VCC_RF_OUT	P	PROVIDE VOLTAGE FOR ACTIVE ANTENNA	3.3V±5%
18	GND	P	GROUND	
19	RF_IN	RF	GPS RF SIGNAL INPUT	Impedance 50
20	GND	P	GROUND	
21	GND	P	GROUND	
22	GND	P	GROUND	

9. Software Interface

NMEA Protocol

NMEA Output Messages: the Engine board outputs the following messages as shown in Table 1:

Table 1 NMEA-0183 Output Messages

NMEA Record	Description
GGA	Global positioning system fixed data
GSA	GNSS DOP and active satellites
GSV	GNSS satellites in view
RMC	Recommended minimum specific GNSS data
GLL	Geographic position – latitude/longitude
VTG	Course over ground and ground speed

GGA-Global Positioning System Fixed Data

Table 2 contains the values of the following example:

\$GPGGA, 161229.487, 3723.2475, N, 12158.3416, W, 1, 07, 1.0, 9.0, M, , , ,0000*18

Table 2 GGA Data Format

Name	Example	Units	Description
Message ID	\$GPGGA		GGA protocol header
UTC Position	161229.48 7		hhmmss.sss
Latitude	3723.2475		ddmm.mmmm
N/S Indicator	N		N=north or S=south
Longitude	12158.341 6		Dddmm.mmmm
E/W Indicator	W		E=east or W=west
Position Fix Indicator	1		See Table 2-1
Satellites Used	07		Range 0 to 12
HDOP	1.0		Horizontal Dilution of Precision
MSL Altitude	9.0	meters	
Units	M	meters	
Geoid Separation		meters	
Units	M	meters	
Age of Diff. Corr.		second	Null fields when DGPS is not used
Diff. Ref. Station ID	0000		

Checksum	*18		
< CR > < LF >			End of message termination

Table 3 Position Fix Indicators

Value	Description
0	Fix not available or invalid
1	GPS SPS Mode, fix valid
2	Differential GPS, SPS Mode, fix valid
3-5	Not Supported
6	Dead Reckoning Mode, fix valid

GSA-GNSS DOP and Active Satellites

Table 4 contains the values of the following example:

\$GPGSA, A, 3, 07, 02, 26, 27, 09, 04, 15, , , , , 1.8,1.0,1.5*33

Table 4 GSA Data Format

Name	Example	Units	Description
Message ID	\$GPGSA		GSA protocol header
Mode 1	A		See Table 5
Mode 2	3		See Table 6
ID of Satellite Used	07		Sv on Channel 1
ID of Satellite Used	02		Sv on Channel 2
....		
ID of Satellite Used			Sv on Channel 12
PDOP	1.8		Position Dilution of Precision
HDOP	1.0		Horizontal Dilution of Precision
VDOP	1.5		Vertical Dilution of Precision
Checksum	*33		
< CR > < LF >			End of message termination

Table 5 Mode 1

Value	Description
M	Manual-forced to operate in 2D or 3D mode

A	Automatic-allowed to automatically switch 2D/3D
---	---

Table 6 Mode 2

Value	Description
1	Fix not available
2	2D
3	3D

GSV-GNSS Satellites in View

Table 7 contains the values of the following example:

\$GPGSV, 2, 1, 07, 07, 79, 048, 42, 02, 51, 062, 43, 26, 36, 256, 42, 27, 27, 138, 42*71

\$GPGSV, 2, 2, 07, 09, 23, 313, 42, 04, 19, 159, 41, 15, 12, 041, 42*41

Table 7 GSV Data Format

Name	Example	Units	Description
Message ID	\$GPGSV		GSV protocol header
Total Number of Messages ¹	2		Range 1 to 3
Messages Number ¹	1		Range 1 to 3
Satellites in View	07		
Satellite ID	07		Channel 1(Range 1 to 32)
Elevation	79	degrees	Channel 1(Range 00 to 90)
Azimuth	048	degrees	Channel 1(True, Range 000 to 359)
SNR (C/No)	42	dBHz	Channel 1(Range 0 to 99, null when not tracking)
Satellite ID	27		Channel 4(Range 01 to 32)
Elevation	27	degrees	Channel 4(Range 00 to 90)
Azimuth	138	degrees	Channel 4(True, Range 000 to 359)
SNR (C/No)	42	dB-Hz	Channel 4(Range 00 to 99, null when not tracking)
Checksum	*71		
< CR > < LF >			End of message termination

¹Depending on the number of satellites tracked multiple messages of GSV data may be required.

RMC-Recommended Minimum Specific GNSS Data

Table 8 contains the values of the following example:

\$GPRMC, 161229.487, A, 3723.2475, N, 12158.3416, W, 0.13, 309.62, 120598, , *10

Table 8 RMC Data Format

Name	Example	Units	Description
Message ID	\$GPRMC		RMC protocol header
UTC Time	161229.487		hhmmss.sss
Status	A		A=data valid or V=data not valid
Latitude	3723.2475		ddmm.mmmm
N/S Indicator	N		N=north or S=south
Longitude	12158.3416		dddmm.mmmm
E/W Indicator	W		E=east or W=west
Speed Over Ground	0.13	knots	True
Course Over Ground	309.62	degrees	
Date	120598		ddmmyy
Magnetic Variation		degrees	
Variation sense			E=east or W=west (Not shown)
Mode	A		A=Autonomous, D=DGPS, E=DR
Checksum	*10		
<CR><LF>			End of message termination

VTG-Course Over Ground and Ground Speed

Table 9 contains the values of the following example:

\$GPVTG,79.65,T,M,2.69,N,5.0,K,A*38

Table 9 VTG Data Format

Name	Example	Units	Description
Message ID	\$GPVTG		VTG protocol header
Course over rground	79.65	degrees	Measured heading
Reference	T		True
Course over ground		degrees	Measured heading
Reference	M		Magnetic
Speed over ground	2.69	Knots	Measured speed
Units	N		Knots
Speed over ground	5.0	Km/hr	Measured speed
Units	K		Kilometer per hour
Mode	A		A-autonomous, D=DGPS, E=DR
Checksum	*38		
<CR><LF>			End of message termination

GLL-Geographic Position – Latitude/Longitude

Table 10 contains the values of the following example:

\$GPGLL,2503.6319,N,12136.0099,E,053740.000,A,A*52

Table 10 GLL Data Format

Name	Example	Units	Description
Message ID	\$GPGLL		GLL protocol header
Latitude	2503.6319		ddmm.mmmm
N/S indicator	N		N=north or S=south
Longitude	12136.0099		Dddmm.mmmm
E/W indicator	E		E=east or W=west
UTC Time	053740.000		hhmmss.sss
Status	A		A=data valid or V=data not valid
Mode	A		A=autonomous, D=DGPS, E=DR
Checksum	*52		
<CR><LF>			End of message termination

10. Package Specification and Order Information

Shipment Method: Tape and reel

SMT type with stamp holes (22 holes)

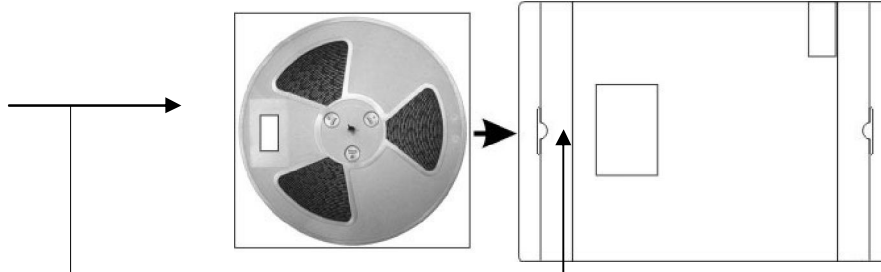

11. Contact Royaltek

Contact: sales@royaltek.com

Headquarter:

Address : 4F., No.188, Wen Hwa 2nd Rd., Kuei Shan, Tao Yuan 333, Taiwan

TEL: 886-3-3960001

FAX: 886-3-3960065

Web Site: <http://www.royaltek.com>

Web Site Customer Service: <http://www.royaltek.com/contact>

Revision History

Title	REB-1315S4 GPS Module	
Doc Type	Operational Manual	
Revision Number	Date	Change notice
0.1	20120912	Updated product spec

Copyright © 2012, RoyalTek Company Ltd.